

WORLDS No. 1 Solar Bollard Light





Solar Bollard Lighting®

The Way To A Sustainable Future



Solar Bollard Lighting® (SBL) is the Australian founded lighting design and manufacturing firm who revolutionized the alternative lighting industry over two decades ago by commercializing the world's first, **Integrated All-in-One Solar Light**.

Solar Bollard Lighting® is the only ISO9001 & ISO14001 certified solar lighting manufacturer that can deliver only top tier solar lights that

- Are fit for commercial purpose
- Have the longest operational life cycles
- Are 100% recyclable at end of life - ensuring zero waste
- Tested and certified in NATA accredited laboratories
- Has an industry leading 10-year product warranty*
- Offers the best ROI on a life-cycle basis

SBL are the pioneers of solar lighting projects that required alternative solutions to enhance public safety and livability at night, such as

- Pathway, trail and stairway lights
- Driveway lighting
- Recreation area lighting
- Dock and marina lighting
- Street and minor road lighting
- Parking lot lighting

Our Original Product Designs

Focusing on industrial grade design, and one product line only that is rigorously evaluated in an Australian NATA accredited laboratory, guarantees our solar lights are fit for commercial lighting projects.

With all great products, many have tried to duplicate our original design innovations, and some may even look similar, but they cannot match our finish quality, long in situ life cycle, and all night illumination. **SBL outshine and outperform all of our competitors.**

Lighting Up Our World

Over 50,000 solar bollard lights are lighting up in over 40 countries, so this assures our clients only a top-tier solar light is delivered, and a superior long-term lighting investment is achieved.

Lighting Adverse Environments

Our solar bollard lighting range is market proven to light up the most challenging environments that are susceptible to

- Cat 5 hurricane/cyclone/typhoon wind speeds occurring
- Full submersion from flooding, tidal surges and tsunamis
- No direct sunlight (full shade every day) occurring**
- Being encased in ice from severe snow blizzard events

Product Features

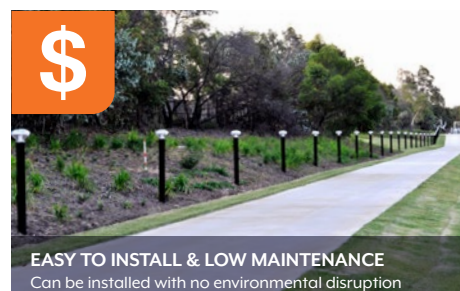
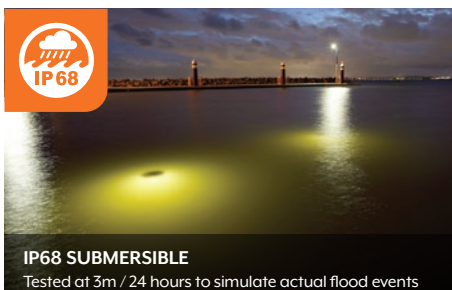

All-in-One Industrial Grade Solar Bollard Lighting

IP68

IK10

SBL2 Series

SUITED TO

- Flood Prone Areas
- Shaded Locations
- Snowfall Regions
- Monsoonal Locations
- Environmental Areas



10 YEARS
WARRANTY • PRODUCT AND PERFORMANCE



SBL2 S MODEL
General Lighting
3000K DarkSky Compliant



SBL2 SR
Full Light Cut Off
DarkSky Compliant



SBL2 WLF
Wildlife Sensitive
Locations

POLE FINISHES



POWDER COATED



ANODISED

LIGHT DISTRIBUTION OPTIONS



ASYMMETRICAL



SYMMETRICAL

LED OPTIONS



4000K
Natural White



3000K
Warm White



600nm-615nm
Wildlife Friendly

INSTALLATION & MOUNTING OPTIONS

The 6106 T6 high tensile strength marine grade aluminium used to extrude our poles, offers an operational life of up to 30 years in situ.



Baseplate Mount
Ground mounted to existing or new surfaces



WM
Wall Mounted



PM
Pylon Mounted



UM
Fence Mounted



RR
Round Rail Mounted



RR
Square Rail Mounted



Baseplate Cover
Option to cover the baseplate securing bolts



Direct Buried
Simple core hole and concrete fill for maximum security



OH
1 Light Head



2OH
2 Light Head



3OH
3 Light Head



4OH
4 Light Head

TECHNICAL SPECIFICATIONS

DOME POLYMER	SABIC Lexan™ SLX Copolymer (Extreme UV Resistance)
HOUSING POLYMER	SABIC 703RPC (High Impact Resistance / High UV Stabilised)
INTERNAL POLYMER	Starex ASA Copolymer
SR REFLECTOR Optional	External 304SS Powder Coated External Aluminium Anodised (over 2.5m only)
LED CHIP	8 x 5mm SuperFlux LED - 4000K (Natural White) - 3000K (Warm White - DarkSky Compliant) - 585nm-615nm (Wildlife Friendly)
VOLTAGE	3.2VDC (ELV intrinsically safe - No UL certification required for USA)
OPERATE TEMP	-30°C ~ +60°C ambient (runs safely up to 100°C)
MAINTENANCE	Annual wash and polish (for peak performance)
WARRANTY TERM	10 Years - includes battery and pole* *subject to SBL Warranty T&Cs
CERTIFICATIONS	IP68 – (AS/NZS 60529:2004 IPx8, IP4x, IP6x) IK10 – (IEC 62262:2002) Photometry – (IESNA LM-79-08) CE
LUMINAIRE WEIGHT	2.88kg (6.4lbs) NW / Add SR 4.21kg (9.3lbs) NW

SOLAR MODULE - ROHS Compliant	
Pmp	5w Mono-Crystalline
Voc / Vmp (V)	6V / 5V
Isc / Imp (A)	1.15 A / 1.01 A
Design Life	>12 Years - 100%
BATTERY	
Type	3.2V 17Ah Cylindrical LiFePo4
Cycle Life	>5000
Design Life	>13.7 Years
ELECTRONICS - ROHS Compliant	
Design Life	20 Years - Long Life Analogue Circuit
Runtime	Dusk until Dawn @ full power
On/Off	Solar Panel Voltage
POLE MATERIAL AND COMPONENTS	
Material	Extruded 6106 T6 Aluminium
Grade	Marine / High Tensile / Light Weight
Durability	High Corrosion Resistance
Collar	Spun Aluminium 25um Anodised
Hardware	Security Bolts 4 x M6 - 316 SS

ORDERING MATRIX

POWER MODEL	LED CONFIGURATION	MOUNTING CODE	DIMENSION	INSTALLED HEIGHT	POLE FINISH OPTIONS
040 - 40mA	ANW	-130WM	130mm/5.1"	290mm / 11.4"	STANDARD FINISH A - 25um Anodised Silver (Default Colour) AB - 25um Black Anodised (Default Colour) PC - Black Satin (Default Colour) CUSTOM FINISH AC - 25um Anodised - Various Colours* ES - EverShield Anodised - Various Colours* PCC - Powder Coat - Various Colours* NOTES: * Custom Order Options have longer lead time * Under 15 poles - Minimum Order Loading cost applies
080 - 80mA	SNW	-142BP	142mm/5.6"	302mm / 11.9"	
120 - 120mA	AWW	-292R RR/SR/DP/UM	1840mm/79"	2000mm / 79"	
160 - 160mA	SWW	-840BP	840mm/33"	1000mm / 39.4"	
200 - 200mA	LED DESCRIPTION	-1140DB	1140mm/44.9"	1000mm / 39.4"	
240 - 240mA	ANW Asymmetrical (180°) 4000K LED	-1340BP	1340mm/53"	1500mm / 59"	
280 - 280mA	SNW Symmetrical (360°) 4000K LED	-1790DB	1790mm/70.4"	1500mm / 59"	
	AWW Asymmetrical (180°) 3000K LED	-1840BP	1840mm/79"	2000mm / 79"	
	SWW Symmetrical (360°) 3000K LED	-2440DB	2440mm/96.5"	2000mm / 79"	
SR REFLECTOR OPTION		-2340BP *2/*3/*4	2340mm/92"	2500mm / 98"	
SRS - Add SR Reflector 304SS Powder Coated		-30402DB	3040mm/119.6"	2500mm / 98"	
SRA - Add SR Reflector Aluminium Anodised		-2840BP *2/*3/*4	2840mm/111.8"	3000mm / 118"	
		-3640DB	3640mm/143"	3000mm / 118"	
		-3340BP *2/*3/*4	3340mm/131.5"	3500mm / 138"	
		-3840BP *2/*3/*4	3840mm/151"	4000mm / 157"	
		-4340BP *2/*3/*4	4340mm/171"	4500mm / 177"	

Ordering Example :

SBL2-160ANW-SR-840BP-CA-BPC = 160mA Asymmetrical Natural White LED with SR Reflector on 840mm/33" Black 25um Anodised Pole with Anodised Base Plate Cover

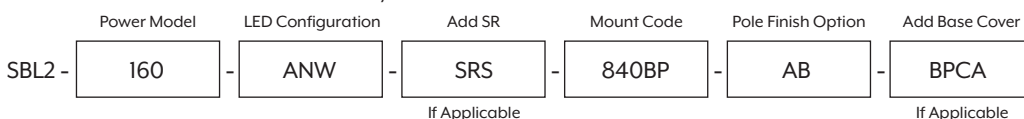

NOTES: Specifications subject to change without notice

Applications

Our Australian Made solar bollard light can be found in more than 40 countries, lighting up projects such as pathways, streets, driveways, stairways, public jetties and pontoons, and even flag poles.



PATHWAYS



JETTY & DOCKS



STAIRWAY & ACCESS WAYS



WETLANDS



RESIDENTIAL DEVELOPMENTS



PARKS & PUBLIC AREAS



SNOW REGIONS



RESIDENTIAL STREETS



MARINE & WILDLIFE AREAS

Industries

There are many reasons architects, landscape designers, facility managers, town planners, developers, civil contractors, mining & resource companies, and governments from around the world choose the SBL2 Series.



LOCAL GOVERNMENT



STATE GOVERNMENT



CORPORATE - INSTITUTIONS



MINING - OIL - GAS

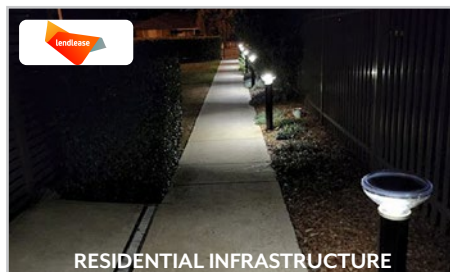

RESIDENTIAL INFRASTRUCTURE

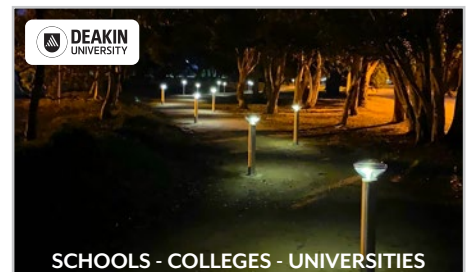

SCHOOLS - COLLEGES - UNIVERSITIES



HOTELS - RESORTS - CAMP GROUNDS



SPORTS - RECREATION

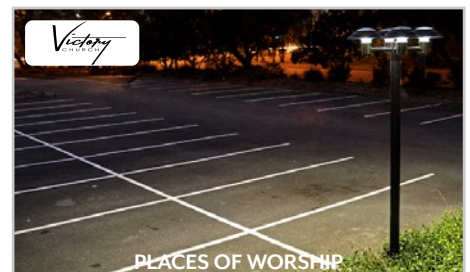

PLACES OF WORSHIP

Standard Pole Range

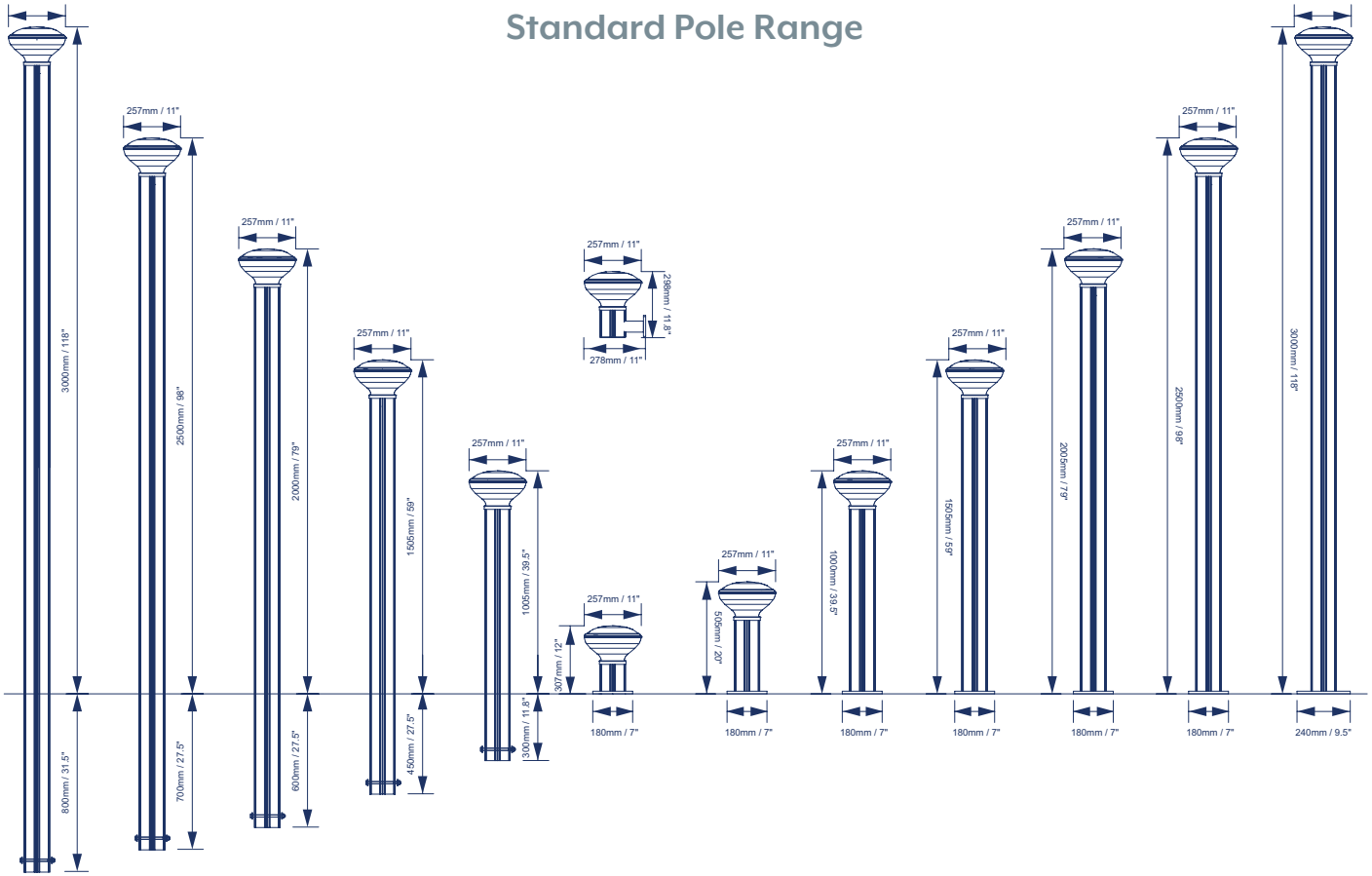

Multi Light Pole Range

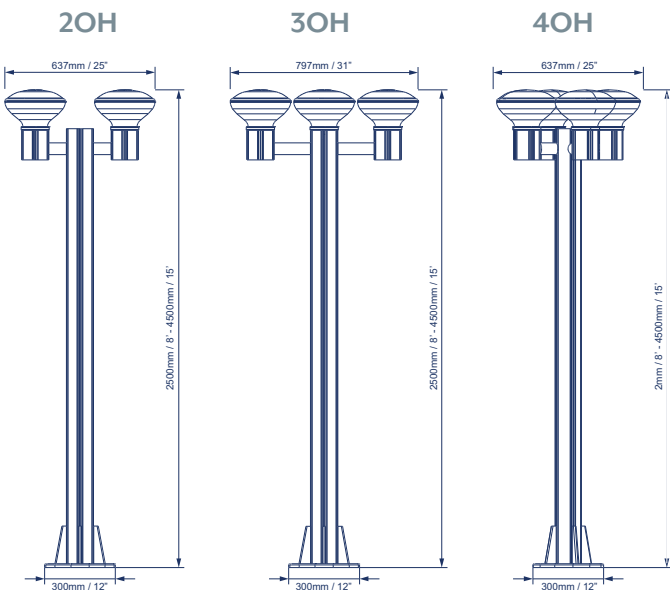

Conveyor / Rail Mount Pole Range

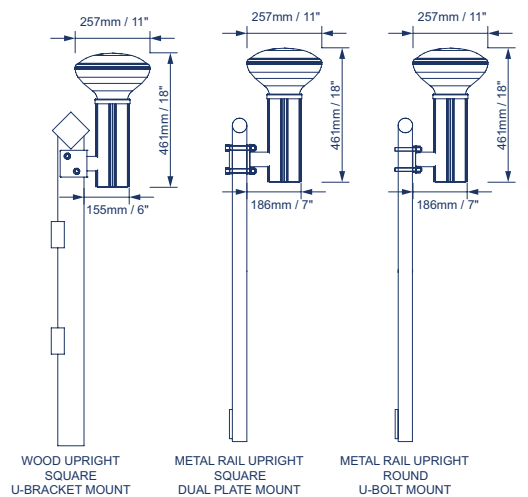

Example of clients using our lighting



READY FOR CLIMATE-DRIVEN SEA LEVEL RISE AND FLOODING

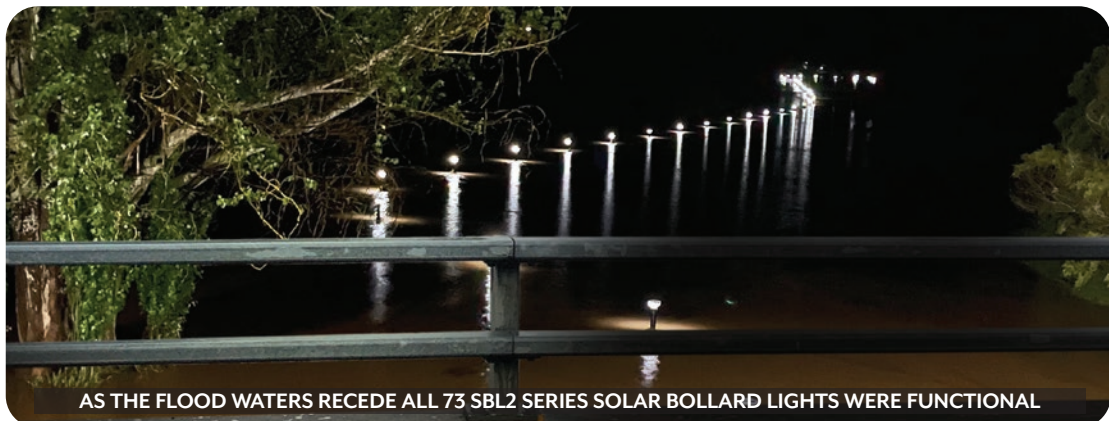

BUCHAN CAVE RESERVE - PARKS VICTORIA - TESTIMONIAL

"The (Solar Bollard) lights down on the river flat are working amazingly, they have even been fully submerged by 2 floods and still all good." I'd definitely recommend these lights in high environmental risk areas."

**Jordan Gardiner | Parks Victoria
Ranger Team Leader | Buchan Caves Reserve**

Available through our national distributor network:

HIGHLUX

SMART OUTDOOR LIGHTING

VIC | TAS | SA | WA

103 Camberwell Road
Hawthorn East VIC 3123
1300 884 724
referrals@highlux.com.au



www.solarbollardlighting.com